

V.V. Korobiichuk, Ph.D.  
 O.M. Sidorov, a post-graduate student  
 R.V. Sobolevskiy, Ph.D.  
 V.O. Shlapak, Ph.D.  
 A.O. Kryvorushko, Ph.D.  
 Zhytomyr State Technological University

## EUROPEAN INTEGRATION: TREATMENT OF STONE PROCESSING ENTERPRISES WASTE IN UKRAINE

*Ukraine Stone industry is undergoing dramatic changes. Today is a restructuring of the industry. In a market economy, modernization of existing stone processing enterprises, the use of new technologies in the production of stone products is actually. Analysis of stone processing enterprise activity shows a large variation in quantitative and qualitative indicators, low competitiveness. However, the demand for stone products with traditional characteristics is stored.*

*Waste stone processing enterprises often exported to landfills that are not suited to the storage of waste or unauthorized, and remain there, taking up more and more land area. During the Earth Summit in Rio de Janeiro independent Ukraine declared its intention to be actively involved in global environmental policy and development strategy of sustainable development, implementing guidelines defining international instruments at the national level. Consequently, there is an urgent need for real action on comprehensive recycling stone processing enterprises to obtain a secondary product. It should be noted that the use of modern methods of stone processing enterprises will waste the protection of nature and natural resources, improve the quality of life, restore lost harmony between man and nature.*

*This publication analyzes the level of recycling waste stone processing enterprises. These volumes of industrial waste stone processing enterprises and highlights stone processing companies hand waste I-IV classes of danger Zhitomir region (Ukraine). These waste composition and properties of stone processing enterprises. Principles of artificial and natural lighting water are noted. Mathematical and economical model of the stone processing enterprises are constructed.*

**Keywords:** slurry waste; decorative stone processing; water treatment; bottle.

**Introduction.** Ukraine has an agreement about the association with the European Union, and raw material policy of the EU presupposes the maximum usage of the secondary raw materials for manufacturing goods of the quality relevant to the quality of goods made of natural resources [1].

In the developed countries of the EU manufacturing ready-made goods with using secondary raw materials comprise a great part – in Great Britain (68 mln tons) and in Netherlands (18 mln tons), where the part of goods made of secondary raw materials comprises about 25 % of the total amount of production. The average part of goods made of secondary raw materials for 28 countries comprise 10 % [2].

Stone processing enterprises of Ukraine generate a great amount of waste. Each year the part of stone processing enterprises in producing waste and polluting the environment is drastically growing. Increasing the amount of refuse is caused by the influence of the extensive usage of natural resources; being too outdated; excessive energy- and material – capacity, producing too much waste via processing natural stone, the low level of the secondary processing waste of stone processing enterprises, ineffectiveness of the organizational mechanism of nature using and environmental activity of stone processing enterprises.

**The analysis of literature sources and problem setting.** The problems of ecological and economic grounding effective management of waste were considered in numerous scientific works by Pier Paolo Manca, Giampaolo Orrù & Paolo Desogus [3], López-Buendía [4], T.V. Kolomiyets [5], Soltan A.M., Taman Z. & El-Kaliouby B. [6], I.V. Davydovs [7–11], V.A. Strikha and others; the questions of the ecological management and the ecological policy relating waste policy were considered in the works by B.Danylyshyn [13], E.R.Hubanov [14] and others. At the same time, the questions related to waste of stone processing enterprises are not basically considered in researching the area of national natural resources consumption. It is concerned with some limitations as for the information access, numerous violations while storing and storage of waste by stone processing enterprises, incompleteness of the statistics information.

**Target and aims of the research.** For reaching the aim set the following tasks were fulfilled: to analyze a contemporary level of the secondary waste recycling of stone processing enterprises on purpose to build economic and mathematical model of forming the mode of stone processing enterprises.

**Presentation of the major research material.** The analysis of data given in drawing 1 proves the tendency to increasing the amounts of processing natural stone in Europe. At the same time a sufficient increasing refers to carbonate rocks. It is known that while cutting natural stone blocks the amount of waste comprises 10–25 % of the natural stone block. Rough stone and sludge refer to waste category.

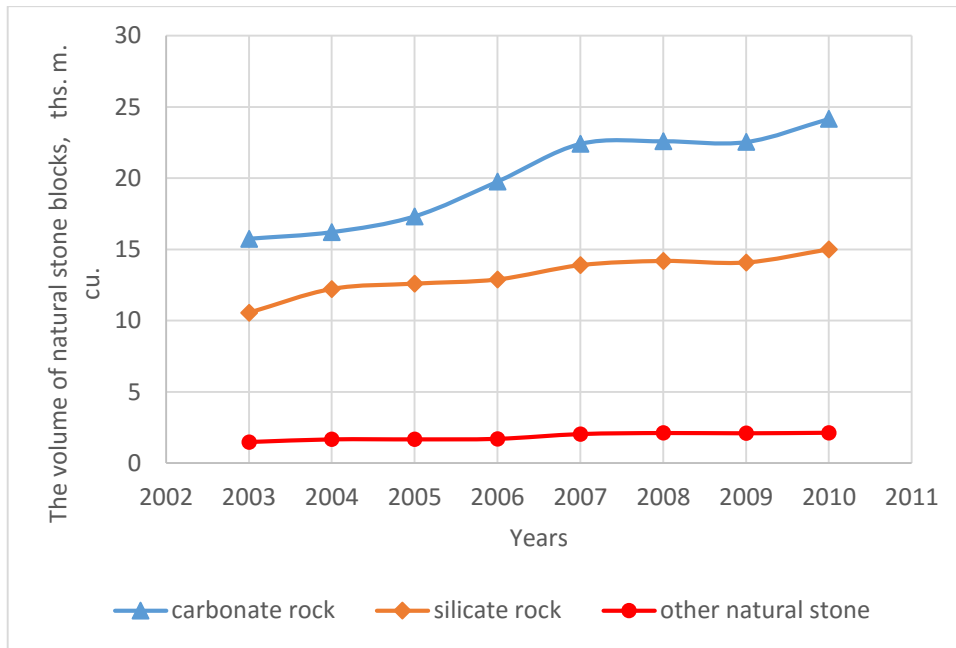

Drawing 1. The amount of processing natural stone in Europe

The Italian researches [14] distinguish two different categories of sludge: from carbonate rock (CS) and silicate rocks (SS). Both categories are minor dispersible. In general CS consist of the same chemical elements and minerals as the stones which are processed (that is marble, limestone, and travertine). Vice versa, SS is characterized by the high level of heavy metals that are the components of the instruments used in the procedure of processing natural stone. In general, waste of stone processing economy according to ILD 152/06 can be used for restoring environment or for cement plants. Construction industry is one of the most potentially interested sectors in the secondary usage of natural stone waste [15–17]. In the countries of EU [18] waste of stone processing for replacing about 60 % of sand and 10 % of cement in concrete and 40 % of clay in ceramic bricks without influence on its hardness and compression.

The amounts of production waste obtained by stone processing enterprises in Zhytomyr Region (Ukraine) are given in Drawing 2.

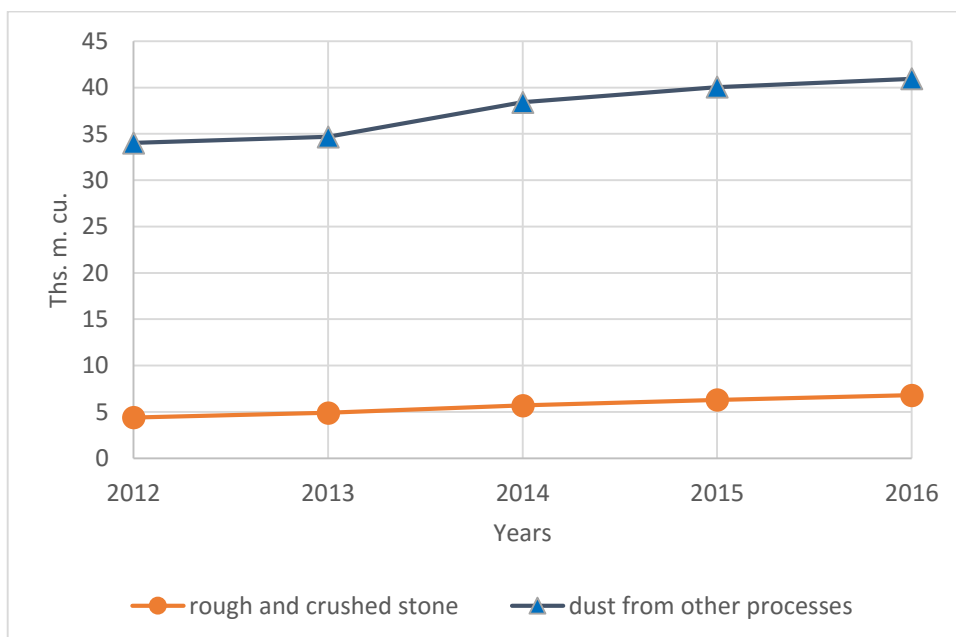

Drawing 2. The amount of production waste of stone processing enterprises

Increasing the amount of waste makes the problem of its utilizing or secondary usage topical. In Ukraine a commonly used method of utilizing solid waste is the method of physical burying under the layer of soil. This method is formal and it only puts off the question of waste utilizing. According to statistics in Ukraine about 1 billion tons of solid waste of production and consumption is produced annually. Only one tenth of them may be used as secondary material resources, the rest gets into storages, sludge accumulators, dirt piles. Solid industrial waste at the contemporary state occupy the area of about 1600 km<sup>2</sup>, and their total amount reached 25 billion tons including 4.5 billion of extremely toxic.

According to data from Table 2, general amounts of utilizing waste by own means of stone processing enterprises for the period 2012–2016 increased by 28.6 %, in general utilizing rough stone and crushed stone. Each year the amount of waste, stored in specially selected places, is increasing, but their part is still low and it only comprises about one fifth of the general waste amount. The greatest part of waste is located on the territory of stone processing enterprises, but in most cases, this territory lies at the background of these enterprises. It ruins and pollutes the land suitable for agricultural cultivation and it ruins the landscape.

Table 2

*The main indexes of treating waste of the 1<sup>st</sup>-4<sup>th</sup> danger class at stone processing enterprises in Zhytomyr region (Ukraine)*

Index	2012	2013	2014	2015	2016
Produced waste, thousands of tons	34,02	34,68	38,4	40,05	40,95
Utilized by own means (processed, recycled)	2,1	2,2	2,3	2,5	2,7
Part of utilized waste, %	18,3	19,0	18,7	19,3	20,6
Removed into specially selected places and objects	1,2	1,4	1,8	2,0	2,2
Part of removed waste, %	11,1	12,3	14,8	15,6	16,5
Specially selected places or objects on the territory of enterprises at the end of the year	8,0	8,0	11,7	8,5	8,4
Part of waste in specially selected places, %	70,8	68,9	95,9	65,3	62,9

European and national experience determine a number of directions of recycling waste at stone processing enterprises. The most perspective one is the usage of waste as supplements into mixtures for manufacturing building materials and constructions, and also replacing natural raw materials while producing cement, concrete, porous fillers, ceramic and silicate bricks. The primary task of a stone processing enterprise is upgrading the system of collecting and sorting out waste, as there are some unloaded powers relevant to this kind of waste.

The main idea in diminishing production of waste or minimizing its appearance lies in substitution of natural resources by waste of stone processing production. This approach implies: technical and organizational improvement of production process of stone processing enterprises; at the state level it is necessary to implement taxation of primary non-ecological raw material, taxes for waste products and production; intensifying responsibility of stone processing enterprises via implementing the motto “waste producer pays the total price of utilizing” as it is conducted in EU, and that will make enterprises reduce waste amount and areas of waste dumps.

Content and properties of waste at stone processing enterprises set the level of their danger for environment and human health and they are referred to production waste [19]. Rough stone and crushed stone refer to the 4<sup>th</sup> class of danger, to inert non-toxic waste. Waste made of rough stone and crushed stone are the most sufficient and comprise about 35-50% of the total amount of stone blocks. Rough stone is used as a building material and a component of concrete. Sludge (minor particles of stone obtained while cutting) are referred to the 4<sup>th</sup> or 3<sup>rd</sup> class of danger, inertial waste. The category of danger is determined by Cr<sub>2</sub>O<sub>3</sub> and CuO in its content. At many enterprises sludge is related to the 3<sup>rd</sup> class of danger due to the excessive content of Cr<sub>2</sub>O<sub>3</sub> та CuO containing in diamond stone processing instrument and polishing powders. Waste of the 3<sup>rd</sup> class danger need a special utilizing. Therefore these types of waste are accumulated in landfills.

As stone processing enterprises process different rocks of a natural stone the problem of sludge sorting occurs as rocks have some differences in their mineral structure [20]. While processing natural stone sludge of different stone rocks is mixed in sludge sump and this makes impossible using it as a supplement as the qualitative content of sludge is not constant.

Exactly due to the mode parameters of the enterprise and the system of water cleaning it is possible to decrease the amount of harmful supplement in the content and to sort out sludge according to the rock type.

There are several systems of water recirculation at stone processing enterprises. These schemes are divided into:

- Sludge economy for strips benches with a free abrasive;

– Sludge economy of stone processing benches.

The most widely spread is a sludge economy of stone processing benches with a natural way of water lightening. Sludge sumps refer to the system of natural water lightening. The characteristic features are being cheap and low maintenance. In sludge sumps water is settled and the result lies in settling solid sludge particles on the bottom. Lightened water is brought to stone processing benches again.

It should be mentioned that the longer way of water movement to sludge sump is, the better is the quality of water lightening. The construction of a sludge sump is depicted in Drawing 3.

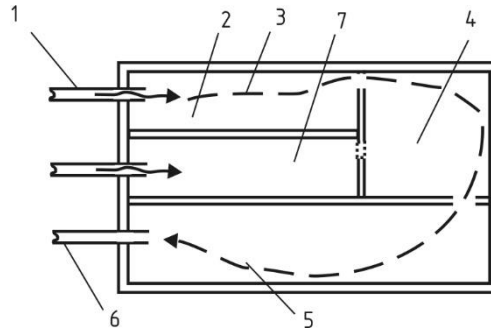

*Drawing 3. The scheme of sludge sump:*

*1 – confluent piping, 2 – inlet part of a sump, 3 – water movement scheme in sludge sump, 4 – intermediate section of a sump, 5 – department of water distribution, 6 – absorbing piping, 7 – extra section of a sump*

Water comes from drain piping into inlet section of a sump, moves to the intermediate department, then it gets to the section of water disbursement and it is brought to the enterprise. A great amount of sludge is settled in the inlet section of a sump, two other sections are appointed for water lightening, therefore they are rather long, and due to this hard parts of sludge settle at the bottom. Extra section of a sump is targeted to provide a normal work of a sludge sump while cleaning inlet section from sludge. In this case drain water is brought to extra section of a sump which goes through intermediate section and water disbursement section to stone processing shop. In the inlet section of a sludge sump waste water access is stopped and sedimentary sludge is dried. Dried sludge is removed by excavator with its further offloading to dump trucks. To accelerate sludge settling coagulants are added to a sludge sump.

It is possible to sort out sludge according to the rock type via sludge economy with the system of artificial water lightening. In EU sludge economy is widely used implying the system of artificial water lightening, and this gets popular in Ukraine, the system of water cleaning and sludge pressing refer to this sludge economy (Drawing2).

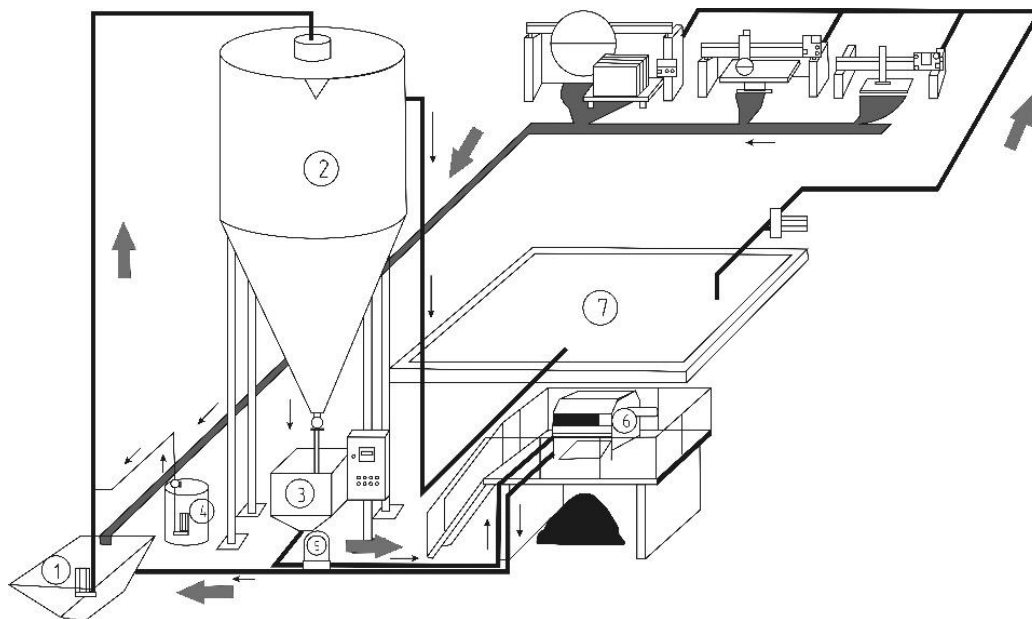

*Drawing 2. Scheme of facility for processing, recycling waste water and sludge drying*

*1 – pump and receptacle for wastewater; 2 – cyclone; 3 – collector for sludge homogenization; 4 – automated station of flocculating agents; 5 – pump of filtering press power; 6 – filtering press; 7 – toolkit of cleaned water*

Work principle of the artificial water lightening lies in the following: polluted water comes from pulp pumping station of the stone processing shop (Drawing 2,1), where the pump is installed and it brings polluted water to the classifier of "cyclone" type (Drawing 2, 2).

While cleaning polluted water flocculating agents are delivered to the cyclone from the automated station of coagulants which favour chaining sludge particles in between.

Water is cleared in the cyclone and comes into the collector of clear water, and then it is carried to the stone processing shop. Sludge obtained after cleaning water in the cyclone, gets in the wet state to the collector of sludge homogenization where it is timed to the homogeneous state and is transported to the filtering press which presses sludge out of water. Dry sludge is stored directly under filtering press, and water, obtained after pressing is transported to the receptacle of wastewater collection, and then it is brought for a follow-up cleaning.

These filtering presses are capable to recycle water from 100 liters per minute till 20000 liters per minute, the amount of the pressed sludge from 0,5 m<sup>3</sup> up to 80 m<sup>3</sup> per 8 hours.

This system allows cleaning water up to 98 % and enables reducing energy consumption (pumping revers water) and minimizing amortization of equipment and materials (diamond disks and abrasives).

The advantages of such systems are:

- work of enterprises without technological breaks necessary for cleaning sludge sump (covers about 2-8 hours of working time);
- compactness of facilities (in comparison with traditional systems the new ones occupy a little space in the shop);
- the conditions of instrument work improve, therefore its runout reduces;
- compactness of sludge accommodation ( in sacks) is provided.
- The disadvantages of such systems are:
- Their high value;
- Expenses for coagulating agents in the working process;
- Service maintenance.

For effective usage of sludge economy with the system of artificial water lightening it is necessary:

- to replace metal link of the existing polishing instrument by the link of the organic origin ( that will reduce heat-resistance of the instrument, in many cases it is impossible);
- to replace outdated toggle-lever benches by semi-automated or automated benches which do not use polishing paste on the basis of Cr<sub>2</sub>O<sub>3</sub>, and in many cases it is impossible as it requires sufficient investment.

Anyway, for correct sorting of different sludge rocks it is necessary to coordinate mode parameters of stone processing enterprise and the type of rocks processed. This, in its turn, will reduce efficiency of stone processing benches. At the same time sludge economy with the system of artificial water lightening will decrease downtime of stone processing enterprise due to regular cleaning of sludge sumps. In average, it will prolong the working time of the enterprise by 20 days per year.

Mode parameters of a stone processing enterprise depend on raw materials market and the market of ready-made goods. A stone processing enterprise may take raw material from own quarries or buy blocks at other quarries.

Stone processing enterprise may release ready-made goods and semi-finished products (slabs).

Producing goods for a storehouse is accounted for only in the case if there is assurance in selling accumulated supply after finishing a short time period. However, taking into account a seasonal demand on decorative stone at the market, as a rule, it is impossible to provide normal loading production powers without issuing products to the storehouse.

For building economic and mathematical model of forming the mode of work at stone processing enterprises the following denominations will be used.

Stone processing enterprises have  $i$  sources of raw materials ( $i = \overline{1, n}$ ). At the same time:

$i = \overline{1, l_2}$  – suppliers of granite raw materials, including: own quarries ( $i = \overline{1, l_1}$ ), external raw materials suppliers  $i = \overline{l_1 + 1, l_2}$ ;  $i = \overline{l_2 + 1, l_4}$  – suppliers of gabro and labradorite, including: own quarries ( $i = \overline{l_2 + 1, l_3}$ ), external suppliers of raw materials ( $i = \overline{l_3 + 1, l_4}$ ).

Stone processing enterprise issues the goods of  $k$  types: slabs ( $k = 1$  – for unpolished slabs,  $k = 2$  – for polished slabs), tiling ( $k = 3$ ), thickness gauge testers ( $k = 4$ ), figured ( $k = 5$ ) i ritual goods ( $k = 6$ ).

Basing on the analysis of production opportunities of a stone processing enterprise, properties of raw materials and type of products made expenses of  $i$  raw material for manufacturing one  $k$  item of products -  $B_{ik}$ .

The power of stone processing enterprises is determined separately for each of the technological processes ( $e = 1$  – cutting,  $e = 2$  – polishing,  $e = 3$  – milling etc.) and groups of rocks (granite, gabro and labradorite). At the same time the known general amount of equipment and proper efficiency of its work at the enterprise –  $A^p$ , efficiency of a stone processing enterprise while dividing the processes of stone cutting and polishing will decrease and it will constitute  $A^p \frac{T_{3ar}}{t_{нол} + t_{поз}}$ , where  $T_{3ar}$  – general time of processing  $i$  raw material of one item of  $k$  products

at the stone processing enterprise without distributing operations of cutting and polishing;  $t_{\text{пол}}$  – time used for polishing  $i$  raw material quantitative products;  $t_{\text{роз}}$  – time used for cutting  $i$  raw material products. Labour-output ratio of processing  $i$  raw material while producing  $k$  good at mode technological process –  $a_{ik}^p$ .

Basing on marketing research of ready-made goods market the maximum amount of demand for each type of goods is determined –  $M_{ik}^{\text{max}}$ .

It is predicted the maximum possible amount of supplying each type of raw materials –  $S_i^{\text{max}}$ . On the basis of formed market conditions possible prices for enterprise products are set –  $\Pi_{ik}$ .

The expenditures of the enterprise for buying one item of raw materials are given  $H_1$ . For blocks got in the quarries of a stone processing enterprise, the price of the raw material is equal to the first cost of mining. For independent suppliers the price of raw materials is established depending on release prices. Besides, expenses for blocks transportation are taken into account (on the basis of  $1\text{m}^3$ ) from the  $i$  supplier to the stone processing enterprise –  $V_i$ . Thus, taking into account per units for manufacturing on item of production –  $B_{ik}$ , the price of raw materials will constitute in the ready-made good –  $B_{ik}(H_i + V_i)$ .

While using sludge economy with the system of artificial water lightening a stone processing enterprise will have additional expenses for maintenance of facilities of sludge economy –  $Z$ , downtime due to regular cleaning sludge sump of a stone processing enterprise will reduce, and it will be expressed by the following index –  $j = \frac{T_{\text{piч}}^{\text{unn}}}{T_{\text{piч}}}$ , where  $T_{\text{piч}}^{\text{unn}}$  – annual amount of working hours of a stone processing enterprise with sludge economy and artificial water lightening;  $T_{\text{piч}}$  – annual amount of working hours of a stone processing enterprise with natural water lightening.

The economic effect from sludge utilizing –  $E$ . The production price of  $k$  products of raw material type –  $Q_{ik}$ . For determining mode parameters of a stone processing enterprise it is offered to apply a developed economic and mathematic model of the optimal application of market, raw and production resources adjusted to market conditions of selling the natural stone. Knowing the average market price of  $k$  products of  $i$  raw materials –  $\Pi_{ik}$  and the first price of its issue, it is necessary to determine the amount of production of  $k$  products made of  $i$  raw materials –  $x_{ik}$ , and they allow providing the maximum consolidated income of enterprises on condition of rational usage of raw material resources.

The model of the task looks in the following way:

- to maximize a target function:

$$\sum_{i=1} \sum_{k=1} (\Pi_{ik} - (H_i + V_i)B_{ik} - Q_{ik} - Z + E)jx_{ik} \rightarrow \max, \quad (1)$$

- by limitations:

$$jx_{ik} \leq M_{ik}^{\text{max}},$$

- by market completeness:

$$jx_{ik} \leq M_{ik},$$

- by powerfulness of stone processing equipment:

$$\sum_i \sum_k a_{ik}^p x_{ik} j \leq A^p,$$

- by a positive decision:

$$jx_{ik} \geq 0.$$

Nowadays it is extremely topical to work out organizational and economic mechanism of stimulating rational and effective treatment of waste at stone processing enterprises.

Rough stone and sludge refer to waste of stone processing enterprises. At many enterprises sludge relates to the 3<sup>rd</sup> class of danger because of the excessive content of  $\text{Cr}_2\text{O}_3$  and  $\text{CuO}$  containing in brilliant stone processing instrument and polishing powders. All kinds of the 3<sup>rd</sup> class waste need a special utilizing. They are the very kind to be utilized slowly and therefore they are being accumulated in waste dumps. It is possible to sort out sludge with the help of sludge economy with the system of artificial lighting water.

Anyway, in order to sort out sludge of different rocks it is necessary to subordinate mode parameters of a stone processing enterprise and the type of rocks being processed. This, in its turn, will decrease the productiveness of stone processing benches. At the same time sludge economy with the system of artificial water lighting will decrease passive periods at work of a stone processing enterprise which take place due to cleaning sludge waste dump. In average, it will prolong work at the enterprise by 20 days per year.

**Conclusion.** This work is aimed at giving the information as for coping with waste from stone processing enterprises.

Some thoughts are listed below:

- to decrease the amount of waste via decreasing the amount of processing natural stone is impossible because of its economic importance for society in general;
- secondary usage of stone processing waste is a desirable variant, at the same time burying at the waste dumps is a worse decision;
- utilizing waste of stone processing demands initial capital investment and therefore it may make ready made goods of natural stone more expensive, but it may decrease polluted areas;
- secondary usage of stone processing waste is not profitable for most of the mining companies;

- further research is necessary to find out new directions of the secondary usage of natural stone waste that can be economically beneficial for stone manufacturers;
- there is a big potential for improving ecological activities of stone processing enterprises.

#### Список використаної літератури:

1. Koziol W. Bezpieczeństwo pracy i system ratownictwa górniczego w kopalniach odkrywkowych w Polsce / *W.Koziol, A.Borc, L.Machniak, A.Ciepliński* // *Przegląd Górniczy*. – 2015.– 12 (71). – Cz. 2.
2. Canova J.A. Dry ripened mortar with quarry waste and rubber powder from unserviceable tires / *J.A. Canova, G. D. A. Neto, R.Bergamasco* // *Acta Scientiarum. Technology*. – 2015. – Т. 37. – № 1. – p. 25.
3. *Pier Paolo Manca* Recycling of sludge from ornamental stone processing as resource in civil constructions / *Pier Paolo Manca, Giampaolo Orrù & Paolo Desogus* // *International Journal Of Mining, Reclamation And Environment*. – 2015.– Volume 29. – Issue 2.
4. López-Buendía, Angel M. Energy efficiency contribution of the natural stone: approach in processing and application / *López-Buendía, M. Angel* // *Proceedings of global stone congress, Alicante*. – 2010.
5. *Коломієць Т.В.* Стратегія поводження з відходами каменеобробними підприємствами / *Т.В. Коломієць* // *Економіка. Фінанси. Менеджмент: актуальні питання науки і практики*. – 2016. – № 3. – С. 107–120.
6. *Soltan A.M.* Recycling of ornamental stones hazardous wastes / *A.M. Soltan, Z.Taman, B. El-Kaliouby* // *Natural Resources*. – 2011. –№ 2 (04). – p. 244.
7. *Давидова І.В.* Оцінка фізико-хімічних властивостей лісових ґрунтів у зоні техногенного впливу щєбєневих кар'єрів на Житомирському Поліссі / *І.В. Давидова* // *Агроєкологічний журнал. Спеціальний випуск*. – 2010. – С. 74–81.
8. *Давидова І.В.* Оцінка впливу Житомирського міського звалища побутових відходів на гідрологічний режим прилеглих територій / *І.В. Давидова, М.Б. Мянєвська, З.М. Шелєст* // *Збірник наукових праць Подільського державного аграрно-технічного університету. Спеціальний випуск*. – 2010. – С. 70–72.
9. *Давидова І.В.* Дослідження змін фізико-механічних властивостей вторинного поліетилєнєрафтолату, що зберігаються на звалищі міста Житомира / *І.В. Давидова, І.Г. Коцюба, А.В. Лєченко, Г.В. Кірейцева* // *Вісник Житомирського національного агроєкологічного університету*. – № 1 (26). – 2010. – С. 26–30.
10. *Давидова І.В.* Застосування програмного забезпечення з метою оптимізації системи поводження з побутовими відходами міста Житомира / *І.В. Давидова, А.В. Лєченко, І.Г. Коцюба* // *Вісник аграрної науки Причорномор'я*. – № 3 (60). – Миколаїв, 2011. – С. 178–183.
11. *Давидова І.В.* Динаміка вмісту гумусу та нітрогену у лісових ґрунтах у зоні впливу техногенних викидів щєбєневих кар'єрів Житомирського Полісся / *І.В. Давидова, З.М. Шелєст, В.А. Гайченко* // *Вісник Національного агроєкологічного університету*. – № 125. – Київ, 2008. – С. 102–107.
12. *Коробійчук В.В.* Геометризація супутньої корисної копалини в умовах Лєзниківського родовища гранітів та гірничо-геометричний аналіз його показників / *В.В. Коробійчук, О.О. Кісєль, В.А. Стрїха* // *Вісник Національного університету водного господарства та природокористування / Технічні науки*. – 2012. – № 2 (58). – С. 175–184.
13. *Данилишин Б.М.* Наукові нариси з економіки природокористування: монографія / *Б.М. Данилишин*. – К. : РВПС України НАН України, 2008. – 280 с.
14. *Губанова Е.Р.* Механизм экономико-экологического стимулирования использования вторичных ресурсов : монография / *Е.Р. Губанова*. – Одесса : Одесский государственный экологический университет, 2009. – 280 с.
15. *Careddu N.* Reuse of residual sludge from stone processing: differences and similarities between sludge coming from carbonate and silicate stones – Italian experiences / *N.Careddu, G.A. Dino* // *Environmental Earth Sciences*. – 2016. – Т. 75. – № 14. – С. 1–9.
16. *Vieira C.M.F.* Incorporation of granite waste in red ceramics / *C.M.F. Vieira, T.M. Soares, R. Sánchez, S.N. Monteiro* // *Materials Science and Engineering*. – 2004. – № 373. – С. 115–121.
17. *Menezes R.R.* Use of granite sawing wastes in the production of ceramic bricks and tiles / *R.R. Menezes, H.S. Ferreira, G.A. Neves, H. de L. Lira, H.C. Ferreira* // *Journal of the European Ceramic Society*. – 2005. – № 25. – С. 1149–1158.
18. *Segadaes A.M.* Using marble and granite rejects to enhance the processing of clay products / *A.M. Segadaes, M.A. Carvalho, W.Acchar* // *Applied Clay Science*. – 2005. – № 30. – С. 42– 52.
19. ГОСТ 12.1.007-76. Система стандартів безпеки праці. Шкідливі речовини. Класифікація і загальні вимоги безпеки.
20. *Іськов С.С.* Формування забарвлення декоративного каменю Частина 2. Штучне забарвлення кам'яних виробів / *С.С. Іськов, А.О. Криворучко, В.В. Коробійчук* // *Вісник ЖДТУ / Технічні науки*. – 2011. – №1 (56). – С. 100–108.

#### References:

1. Koziol, W., Borcz, A., Machniak, L. and Ciepliński, A. (2015), "Bezpieczeństwo pracy i system ratownictwa górniczego w kopalniach odkrywkowych w Polsce", *Przegląd Górniczy*, Vol. 12 (71), Cz. 2.
2. Canova, J. A., Neto, G. D. A. and Bergamasco, R. (2015), "Dry ripened mortar with quarry waste and rubber powder from unserviceable tires", *Acta Scientiarum. Technology*, Vol. 37. (1), P. 25.

3. Pier, P.M., Giampaolo, O. and Paolo, D. (2015), "Recycling of sludge from ornamental stone processing as resource in civil constructions", *International journal of mining, Reclamation and environment*, Vol. 29, Issue 2.
4. López-Buendía and Angel M. (2010), "Energy efficiency contribution of the natural stone: approach in processing and application. Proceedings of global stone congress", *Alicante*.
5. Kolomiyez', T.V. (2016), "Strategiya povodzhennya z vidxodamy` kameneobrobny`my` pidpry`yemstvamy`" [Strategy for waste management enterprises stone], *Economy. Finances. Management: issues of science and practice*, Vol. 3, pp. 107–120.
6. Soltan, A.M., Taman, Z. and El-Kaliouby, B. (2011), "Recycling of ornamental stones hazardous wastes", *Natural Resources*, 2(04), P. 244.
7. Davy`dova, I.V. (2010), "Strategiya povodzhennya z vidxodamy` kameneobrobny`my` pidpry`yemstvamy`" [Estimation of physical and chemical properties of forest soils in the area of man-made impact crushed stone quarries in Zhytomyr Polissya], *Agroecology magazine. Special issue*, pp. 74–81.
8. Davy`dova, I.V., Myanovska, M.B. and Shelest, Z.M. (2010), "Ocinka vply`vu Zhy`tomy`rs`kogo mis`kogo zvaly`shha pobutovy`x vidxodiv na gidrologichny`j rezhy`m pry`legly`x tery`torij`" [Assessing the impact of Zhytomyr city dump waste in the hydrological regime of adjacent areas], *Proceedings of Podolsky State Agricultural and Technical University. Special Issue*, pp. 70–72.
9. Davy`dova, I.V., Kotsyuba, I.G., Ilchenko, A.V. and Kireytseva, G.V. (2010), "Doslidzhennya zmin fizy`ko-mexanichny`x vlasty`vostej vtory`nnogo poliety`lenteraftolatu, shho zberigayut`sya na zvaly`shhi mista Zhy`tomy`ra`" [Research changes the physical and mechanical properties of secondary poliety`lenteraftolatu stored in a landfill in Zhytomyr], *Bulletin Zhytomyr National Agroecological University*, № 1 (26), pp. 26–30.
10. Davy`dova, I.V., Ilchenko, A.V. and Kotsyuba, I.G. (2011), "Zastosuvannya programnogo zabezpechennya z metoyu opty`mizaciyi sy`stemy` povodzhennya z pobutovy`my` vidxodamy` mista Zhy`tomy`ra`" [The use of software to optimize the system of household waste in Zhytomyr], *Bulletin Agricultural Science of Black Sea*, № 3 (60), pp. 178–183.
11. Davy`dova, I.V., Shelest, Z.M. and Haychenko, V.A. (2008), "Dy`namika vmistu gumusu ta nitrogeneru u lisovy`x g`runtax u zoni vply`vu texnogenny`x vy`ky`div shhebenevy`x kar`yeriv Zhy`tomy`rs`kogo Polissya`" [Dynamics of humus content and nitrogen in forest soils in the area of influence of anthropogenic emissions of crushed stone quarries Zhytomyr Polissya], *Proceedings of the National University of agroecological*, № 125, pp. 102–107.
12. Korobiichuk, V.V., Kysel, A.A. and Strikha, V.A. (2012), "Geometry`zaciya suputn`oyi kory`snoyi kopaly`ny` v umovax Lezny`kivs`kogo rodovy`shha granitiv ta girny`cho-geometry`chny`j analiz jogo pokazny`kiv`" [Geometrization related minerals in terms Leznykivskoho granite deposits and mining and geometrical analysis of its performance], *Proceedings of the National University of Water and Environment / Engineering*, № 2 (58), pp. 175–184.
13. Danylyshyn, B.M. (2008), "Naukovi nary`sy` z ekonomiky` pry`rodokory`stuvannya`" [Scientific essays on environmental economics], monograph, 280 p.
14. Gubanov, E.R. (2009), "Mexany`zm ekonomy`ko-ekology`cheskogo sty`muly`rovany`ya y`spol`zovany`ya vtory`chny`x resursov`" [The mechanism of economic and environmental stimulation of the use of secondary resources], monograph, 280 p.
15. Careddu N. and Dino G. A. (2016), "Reuse of residual sludge from stone processing: differences and similarities between sludge coming from carbonate and silicate stones – Italian experiences", *Environmental Earth Sciences*, Vol. 75, Issue 14, pp. 1–9.
16. Vieira C.M.F., Soares T.M., Sánchez R., and Monteiro S.N. (2004) "Incorporation of granite waste in red ceramics", *Materials Science and Engineering*, Vol. A 373, pp. 115–121.
17. Menezes R.R., Ferreira H.S., Neves G.A., Lira H.de L., and Ferreira H. C. (2005), "Use of granite sawing wastes in the production of ceramic bricks and tiles", *Journal of the European Ceramic Society*, Vol. 25, pp. 1149–1158.
18. Segadaes A.M., Carvalho M.A., and Acchar W. (2005), "Using marble and granite rejects to enhance the processing of clay products", *Applied Clay Science*, Vol. 30, pp. 42–52.
19. GOST 12.1.007-76. System safety standards. Hazardous substances. Classification and general safety requirements/
20. Iskov, S.S., Krivoruchko, A.A. and Korobiychuk, V.V. (2011), "Formuvannya zabarvlennya dekoraty`vnoho kamenyu Chasty`na 2. Shtuchne zabarvlennya kam`yany`x vy`robiv`" [Formation color decorative stone Part 2. Artificial coloring stone products], *Bulletin ZSTU. Engineering*, Vol. №1 (56), pp. 100–108.

KOROBIIICHUK Vanentyn Vatslavovych – Ph.D., Associate Professor of Deposits Development Department named after M.T. Bakka, Zhytomyr State Technological University.

Scientific interests:

- mining;
- construction materials;
- computer technologies.



SIDOROV Oleksandr Mykolayovych – a post-graduate student of Deposits Development Department named after M.T. Bakka, Zhytomyr State Technological University.

Scientific interests:

- mining.

SOBOLEVSKYI Ruslan Vadymovych – Ph.D., Associate Professor of Mine Surveying Department, Zhytomyr State Technological University.

Scientific interests:

- mining;
- construction materials.

SHLAPAK Volodymyr Oleksandrovych – Ph.D., Associate professor of Deposits Development Department named after M.T. Bakka, Zhytomyr State Technological University.

Scientific interests:

- mining;
- construction materials;
- computer technologies.

KRYVORUSHKO Andriy Oleksandrovych – Ph.D., Associate Professor of Mine Surveying Department of Zhytomyr State Technological University.

Scientific interests:

- mining;
- mine surveying.

The article was sent to the publishing department on 02.02.2017.